

Overview

The HP SATA optical drives for HP ProLiant servers are offered with an industry-standard SATA interface and are supported on most major operating systems.

The DVD ROM drive is designed to read not only CD ROM and CD R/RW discs but also DVD ROM, DVD RAM, DVD +R/RW and DVD R/RW discs.



HP Half-Height SATA DVD ROM Optical Drive



HP Slim SATA DVD ROM Optical Drive

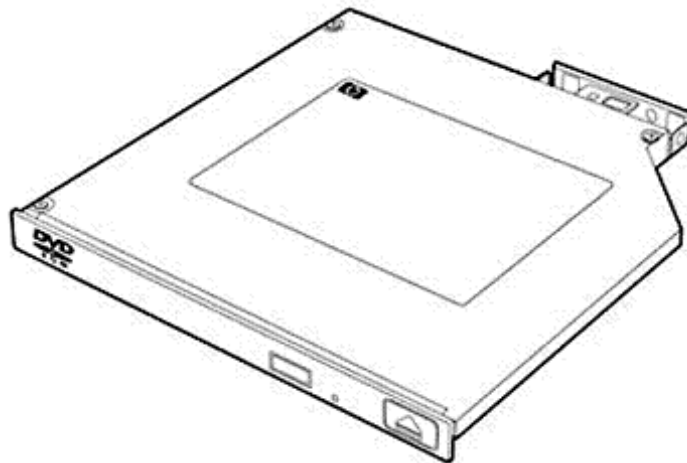

HP 9.5mm SATA DVD ROM Optical Drive

What's New

- Updating list of supported servers
-

Overview

Models

HP Half-Height SATA DVD ROM JackBlack Optical Drive	624189-B21
HP 12.7mm Slim SATA DVD-ROM JackBlack Optical Drive	652232-B21
HP 9.5mm SATA DVD-ROM JackBlack Optical Drive	652238-B21
HP Half-Height SATA DVD-ROM Optical Drive	447326-B21
HP Slim 12.7mm SATA DVD-ROM Optical Drive	481041-B21
HP 9.5mm SATA DVD-ROM Optical Drive	481045-B21

Kit Contents

- SATA DVD ROM drive
- Installation guide
- Warranty card
- Roxio software disk
- SATA data and power cables

Compatibility

HP Half-Height SATA DVD ROM JackBlack Optical Drive

624189-B21

- ProLiant ML (expansion-optimized):**
- HP ProLiant ML310e Gen8
 - HP ProLiant ML310e Gen8 v2
 - HP ProLiant ML350e Gen8
 - HP ProLiant ML350p Gen8

NOTE: This is a list of supported servers. Some may be discontinued.

HP 12.7mm Slim SATA DVD-ROM JackBlack Optical Drive

652232-B21

ProLiant DL (rack-optimized):

- HP ProLiant DL380e Gen8
- HP ProLiant DL380p Gen8
- HP ProLiant DL385p Gen8

NOTE: This is a list of supported servers. Some may be discontinued.

HP 9.5mm SATA DVD-ROM JackBlack Optical Drive

652238-B21

ProLiant DL (rack-optimized):

- HP ProLiant DL160 Gen8
- HP ProLiant DL320e Gen8
- HP ProLiant DL360e Gen8
- HP ProLiant DL360p Gen8

NOTE: This is a list of supported servers. Some may be discontinued.

HP Half-Height SATA DVD-ROM Optical Drive

447326-B21

- HP ProLiant DL370 G6

ProLiant ML (expansion-optimized):

- HP ProLiant ML110 G5
- HP ProLiant ML110 G6
- HP ProLiant ML110 G7
- HP ProLiant ML115 G5



Overview

- HP ProLiant ML150 G6
- HP ProLiant ML310 G5p
- HP ProLiant ML330 G6
- HP ProLiant ML350 G5
- HP ProLiant ML350 G6
- HP ProLiant ML370 G6

ProLiant MicroServer (Just Right First Server):

- HP ProLiant MicroServer

NOTE: This is a list of supported servers. Some may be discontinued.

HP Slim 12.7mm SATA DVD-ROM Optical Drive 481041-B21

ProLiant DL (rack-optimized):

- HP ProLiant DL120 G5
- HP ProLiant DL180 G5
- HP ProLiant DL180 G6
- HP ProLiant DL320 G5p
- HP ProLiant DL370 G6
- HP ProLiant DL380 G6
- HP ProLiant DL380 G7
- HP ProLiant DL385 G5p
- HP ProLiant DL385 G6
- HP ProLiant DL385 G7
- HP ProLiant DL580 G5
- HP ProLiant DL580 G7
- HP ProLiant DL585 G7
- HP ProLiant DL980 G7

ProLiant ML (expansion-optimized):

- HP ProLiant ML370 G6

NOTE: This is a list of supported servers. Some may be discontinued.

HP 9.5mm SATA DVD-ROM ProLiant DL (rack-optimized): Optical Drive 481045-B21

- HP ProLiant DL120 G6
- HP ProLiant DL120 G7
- HP ProLiant DL160 G6
- HP ProLiant DL160se G6
- HP ProLiant DL165 G7
- HP ProLiant DL320 G5p
- HP ProLiant DL320 G6

NOTE: 4 HDD Models only.

NOTE: This is a list of supported servers. Some may be discontinued.

Overview

Warranty

The warranty for this device is 1 year parts only. Maximum: The remaining warranty of the HP server product in which it is installed (to a maximum three-year limited warranty).

- Response - Upgrade on-site response from next business day to same day 4 hours
- Coverage - Extend hours of coverage from 9 hours x 5 days to 24 hours x 7 days
- Duration - Select duration of coverage for a period of 1, 3, or 5 years
- Warranty upgrade options can come in the form of Care Packs, which are sold at the HP System level this product attaches to.

Service and Support

Service and Support

HP Technology Services

HP Technology Services offers you consultants and support experts to solve your most complex infrastructure problems. We help keep your business running, boost availability, and avoid downtime.

Protect your business beyond warranty with HP Care Pack Services

When you buy HP Options, it's also a good time to think about what level of service you may need. HP Care Pack services provide total care and support expertise with committed response choices designed to meet your IT and business need.

HP Foundation Care services deliver scalable support-packages for HP industry-standard servers and software. You can choose the type and level of service that is most suitable for your business needs. New to this portfolio is HP Collaborative Support. If you are running business critical environments, HP offers Proactive Care or Critical Advantage. These services help you deliver high levels of application availability through proactive service management and advanced technical response.

Here is the support service recommendation from the Foundation Care and Proactive Care portfolio. For customized support service solution, HP can work with you to tailor a service solution for your unique support requirements using broader services portfolio of Foundation Care and Proactive Care.

Recommended HP Care Pack Services for optimal satisfaction with your HP product

Recommended Services

3-Year HP 24x7 4 hour Response, Hardware Support Onsite Service

Provides you with rapid remote support and if required an HP authorized representative who will arrive on site any time and day of the year to begin hardware maintenance service within 4 hours of the service request being logged.

<http://h20195.www2.hp.com/V2/GetPDF.aspx/5982-6547EEE.pdf>

OR

3-Year HP 24x7 4 hour Response, HP Collaborative Support

Offers customers a single point of contact for server problem diagnosis, hardware problem resolution, and basic software problem diagnosis, fault isolation, and resolution if available to HP. If the problem is with HP HW, the representative will arrive on site any time and day of the year to begin hardware maintenance service within 4 hours of the service request being logged. In case, the issue is with HP or supported third-party software product and cannot be resolved by applying known fixes, HP will contact the third-party vendor and create a problem incident on your behalf.

HP ProLiant Server Hardware Installation

Provides for the basic hardware installation of HP branded servers, storage devices and networking options to assist you in bringing your new hardware into operation in a timely and professional manner

<http://h20195.www2.hp.com/V2/GetPDF.aspx/5981-9356EN.pdf>

Service and Support

Related HP Care Pack Services to enhance your HP product experience

Related Services

3-Year HP 24x7 4 hour Response, Proactive Care or Critical Advantage

Helps optimize your systems and delivers high levels of application availability through proactive service management and advanced technical response. A skilled Technical Manager will own your query or issue end to end until resolved, delivering a single point of contact for you

<http://h20195.www2.hp.com/V2/GetPDF.aspx/4AA3-2140ENW.pdf>

OR

3-Year HP 6-hour Onsite Call-to-Repair, HP Collaborative Support

Offers customers a single point of contact for server problem diagnosis, hardware problem resolution to return the hardware in operating condition within 6 hours of the initial service request to the HP Global Solution Center, and basic software problem diagnosis, fault isolation, and resolution if available to HP. In case, the issue is with HP or supported third-party software product and cannot be resolved by applying known fixes, HP will contact the third-party vendor and create a problem incident on your behalf.

HP Proactive Select Service

Provides a flexible way to purchase HP best-in-class consultancy and technical services. You can buy Proactive Select Service Credits when you purchase your hardware and then use the credits over the next 12 months.

<http://h20195.www2.hp.com/V2/GetPDF.aspx/4AA2-3842ENN.pdf>

Insight Remote Support

Provides 24 X 7 remote monitoring, proactive notifications, and problem resolution. Learn more

<http://www.hp.com/go/insightremotesupport>

HP Support Center

Personalized online support portal with access to information, tools and experts to support HP business products. Submit support cases online, chat with HP experts, access support resources or collaborate with peers. Learn more <http://www.hp.com/go/hpsc>

HP's Support Center Mobile App* allows you to resolve issues yourself or quickly connect to an agent for live support. Now, you can get access to personalized IT support anywhere, anytime.

HP Insight Remote Support and HP Support Center are available at no additional cost with a HP warranty, HP Care Pack or HP contractual support agreement.

*HP' Support Center Mobile App is subject to local availability

Parts and materials

HP will provide HP-supported replacement parts and materials necessary to maintain the covered hardware product in operating condition, including parts and materials for available and recommended engineering improvements. Supplies and consumable parts will not be provided as part of this service; standard warranty terms and conditions apply. Parts and components that have exceeded their maximum supported lifetime and/or the maximum usage limitations as set forth in the manufacturer's operating manual or the technical product data sheet will not be provided, repaired or replaced as part of this service

Service and Support

Warranty / Service Coverage

For ProLiant servers and storage systems, this service covers HP-branded hardware options qualified for the server, purchased at the same time or afterward, internal to the enclosure, as well as external monitors up to 22" and tower UPS products; these items will be covered at the same service level and for the same coverage period as the server unless the maximum supported lifetime and/or the maximum usage limitation has been exceeded. Coverage of the UPS battery is not included; standard warranty terms and conditions apply.

The defective media retention service feature option applies only to Disk or eligible SSD/Flash Drives replaced by HP due to malfunction. It does not apply to any exchange of Disk or SSD/Flash Drives that have not failed. SSD/Flash Drives that are specified by HP as consumable parts and/or that have exceeded maximum supported lifetime and/or the maximum usage limit as set forth in the manufacturer's operating manual or the technical data sheet are not eligible for the defective media retention service feature option.

For more information

To learn more on services for HP ESSN Options, please contact your HP sales representative or HP Authorized Channel Partner. Or visit: <http://www.hp.com/services/proliant> or www.hp.com/services/bladesystem

Technical Specifications

Data Transfer Rate - Read Speeds	DVD-ROM	Up to 16X
	DVD+R/-R	Up to 16X
	DVD+RW/-RW	Up to 8X
	DVD +R DL/-R DL	Up to 8X
	DVD-RAM	Up to 5X
	CD-ROM/R	Up to 40X
	CD-RW	Up to 32X
Cache Buffer	0.5MB (Minimum)	
Spin-up Time (typical)	less than 10 seconds	(not including tray in)
MTBF	125,000 Power On Hours (POH), 25% Duty Cycle	
Ambient Temperature	Operating	41° to 122° F (5° to 50° C)
	Storage	-22° to 140° F (-30° to 60° C)
Relative Humidity	Operating	10% to 90%
	Storage	5% to 95%

HP Slim SATA DVD-ROM Optical Drive

Shipping Dimensions (HxWxD) 3.97 x 7.81 x 10.75 in (10.08 x 19.84 x 27.31 cm)

Drive Dimensions (HxWxD, maximum) 0.5 x 5.2 x 5.45 in (12.7 x 132 x 138 mm)

Device Type DVD-ROM Drive

Disk **Applicable Disk**

- DVD-ROM
- DVD-R /-RW (Read Only) DVD+R /+RW (Read Only)
- CD-ROM Mode-1 data disc
- CD-ROM Mode-2 data disc
- CD Audio disc
- CD-Extra
- CD-RW (Read Only)
- CD-R (Read Only)
- CD Text
- PhotoCD
- CD-I (mode 2)
- CD-I Ready
- CD-Bridge

Capacity	DVD-ROM	DVD-SL	4.7 GB/side
		DVD-DL	8.5 GB/side
		Double Sided	9.40 GB/side
		DVD+/-R	4.7 GB/side
		DVD-RAM	Ver.2.2, 120 mm 4.7 GB/side
		DVD+R/+RW	4.7 GB

Technical Specifications

		CD-ROM	Mode-1	650 (700 MB)
			Mode-2	742 MB (640 MB)
	Block Size	DVD		2,048 bytes
		CD	Mode-1	2048, 2352 bytes
			Mode-2 Form1	2048, 2328, 2336, 2340 2352 bytes
			Mode-2 Form2	2328, 2336, 2340, 2352 bytes
	Diameter	120 mm, 80 mm (with adapter at vertical mounting mode)		
Loading Mechanism	Tray type Auto Loading			
Interface	SATA 1.5			
Access Times (typical)	Random	DVD-ROM < 160 ms, CD-ROM < 140 ms		
	Full-Stroke	DVD-ROM < 280 ms, CD-ROM < 280 ms		
Data Transfer Rate Read Speeds	DVD-ROM	Up to 8X		
	DVD+RW/-RW	Up to 8X		
	DVD+R DL/-R DL	Up to 8X		
	DVD-RAM	Up to 5X		
	CD-ROM/-R/-RW	Up to 24X		
Spin-up Time (typical)	less than 15 seconds			
MTBF	35,000 Power On Hours (POH), 25% Duty Cycle			
Ambient Temperature	Operating	41° to 122° F (5° to 50° C)		
	Storage/Transportation	-22° to 140° F (-30° to 60° C)		
Relative Humidity	Operating	10% to 80% (non-condensing)		
	Storage/Transportation	5% to 90% (non-condensing)		

HP 9.5mm SATA DVD-ROM Optical Drive

Shipping Dimensions (HxWxD)	3.97 x 7.81 x 10.75 in (10.08 x 19.84 x 27.31 cm)	
Drive Dimensions (HxWxD, maximum)	0.374 x 5.1 x 5.2 in (9.5 x 130 x 132 mm)	
Device Type	DVD-ROM Drive	
Disk	Applicable Disk	DVD-ROM DVD-R /-RW (Read Only) DVD+R /+RW (Read Only) DVD-RAM (Read Only) CD-ROM Mode-1 data disc CD-ROM Mode-2 data disc CD Audio disc CD-Extra CD-RW (Read Only) CD-R (Read Only)

Technical Specifications

		CD Text		
		PhotoCD		
		CD-I (mode 2)		
		CD-I Ready		
		CD-Bridge		
	Capacity	DVD-ROM	DVD-SL	4.7 GB/side
			DVD-DL	8.5 GB/side
			Double Sided	9.40 GB/side
		DVD+/-R		4.7 GB/side
		DVD-RAM	Ver.2.2, 120 mm	4.7 GB/side
		DVD+R/+RW		4.7 GB
		CD-ROM	Mode-1	650 (700 MB)
			Mode-2	742 MB (640 MB)
	Block Size	DVD		2,048 bytes
		CD	Mode-1	2048, 2352 bytes
			Mode-2 Form1	2048, 2328, 2336, 2340 2352 bytes
			Mode-2 Form2	2328, 2336, 2340, 2352 bytes
	Diameter	120 mm, 80 mm (with adapter at vertical mounting mode)		
Loading Mechanism	Tray type Auto loading			
Interface	SATA 1.5			
Access Times (typical)	Random	DVD-ROM < 160 ms, CD-ROM < 140 ms		
	Full-Stroke	DVD-ROM < 300 ms, CD-ROM < 275 ms		
Data Transfer Rate - Read	DVD-ROM	Up to 8X		
Speeds	DVD+R/-R	Up to 8X		
	DVD+RW/-RW	Up to 8X		
	DVD+R DL/-R DL	Up to 8X		
	DVD-RAM	Up to 5X		
	CD-ROM/-R/-RW	Up to 24X		
Spin-up Time (typical)	Less than 15 seconds			
MTBF	35,000 Power On Hours (POH), 25% Duty Cycle			
Ambient Temperature	Operating	41° to 122° F (5° to 50° C)		
	Storage/Transportation	-22° to 140° F (-30° to 60° C)		
Relative Humidity	Operating	10% to 80% (non-condensing)		
	Storage/Transportation	5% to 90% (non-condensing)		

Technical Specifications

**Environment-friendly
Products and Approach****End-of-life Management
and Recycling**

Hewlett-Packard offers end-of-life HP product return, trade-in, and recycling programs in many geographic areas. For trade-in information, please go to <http://www.hp.com/go/green>. To recycle your product, please go to: <http://www.hp.com/go/green> or contact your nearest HP sales office. Products returned to HP will be recycled, recovered or disposed of in a responsible manner.

The EU WEEE directive (2002/95/EC) requires manufacturers to provide treatment information for each product type for use by treatment facilities. This information (product disassembly instructions) is posted on the Hewlett Packard web site at: <http://www.hp.com/go/green>. These instructions may be used by recyclers and other WEEE treatment facilities as well as HP OEM customers who integrate and re-sell HP equipment.

© Copyright 2013 Hewlett-Packard Development Company, L.P.

The information contained herein is subject to change without notice.

Microsoft and Windows are US registered trademarks of Microsoft Corporation.

The only warranties for HP products and services are set forth in the express warranty statements accompanying such products and services. Nothing herein should be construed as constituting an additional warranty. HP shall not be liable for technical or editorial errors or omissions contained herein.